

User Manual

Package Contents

Item	Quantity
Access Point	1
Pole Clamps	2
Mounting Plate	1
M8 x 20 Screws	2
M8 x 60 Expansion Anchors	4
User Manual	1
Cable Gland for SFP Port	1
SFP Port Plug (Pre-installed on the Access Point)	1
Mounting Arm (Pre-installed on the Access Point)	1
Cover of Mounting Arm	1

Ports

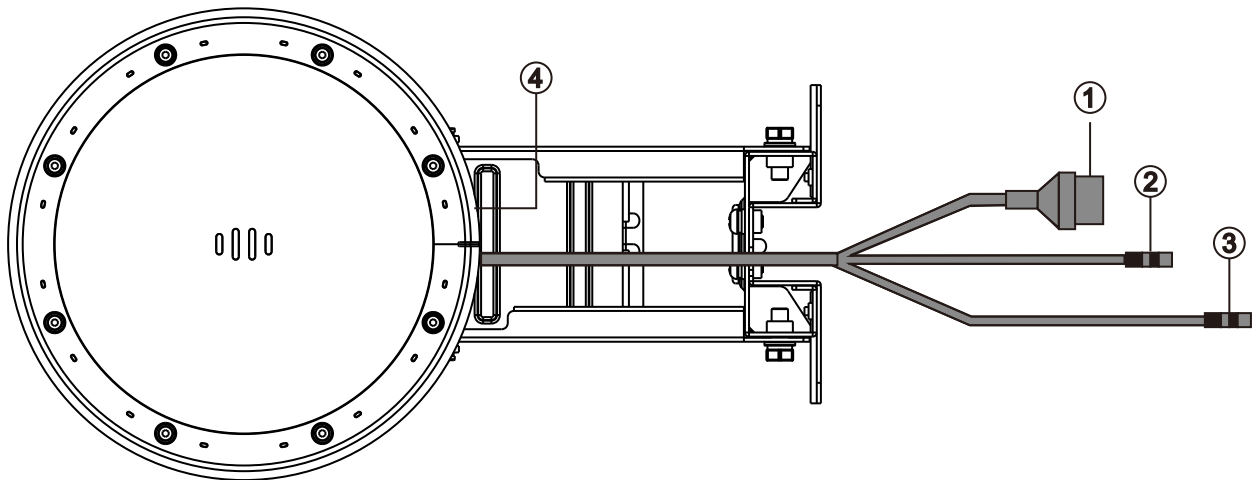

Note: ① LAN/PoE Port
② 12V DC Connector
③ RESET Hole
④ SFP Port

Technical Specifications

Item	Specifications
Dimensions (W x D x H)	230 mm × 230 mm × 195 mm (9.06 in. x 9.06 in. x 7.68 in., without the mounting plate)

Data Rate	2.4 GHz: 574 Mbps 5 GHz: 2402 Mbps Combined: 2976 Mbps
Operating Radio	802.11b/g/n/ax: 2.4 GHz to 2.4835 GHz 802.11a/n/ac/ax: 5.150 GHz to 5.350 GHz, 5.470 GHz to 5.725 GHz, 5.725 GHz to 5.850 GHz
Antenna	Built-in omnidirectional antennas
Service Ports	One 10/100/1000 Base-T Ethernet port (PoE-capable) One 1000 Base-X SFP port
Restart/Reset	Supported
Status LED	Wi-Fi LED, system status LED and port status LED
Power Supply	There are two power supply modes available: 1. Local power supply: 12 V DC /2 A (The adapter is an optional accessory.) 2. IEEE 802.3at (PoE+) power supply
Max Power Consumption	24 W
Environment	Operating temperature: -30°C to 65°C (-22°F to 149°F)
	Storage temperature: -40°C to 85°C (-40°F to 185°F)
	Operating humidity: 0% to 100% (non-condensing)
	Storage humidity: 0% to 100% (non-condensing)
Weight	≤ 1.4 kg (3.09 lbs, without the mounting plate)
Color	Warm white

LEDs and Reset Hole

Item	Status	Description
Wi-Fi LED (Green)	Flashing	Data is transmitted by Wi-Fi.
	Solid on	Wi-Fi is enabled and no data is transmitted.
	Off	Wi-Fi is disabled.
System Status LED (Blue)	Fast flashing	The access point is starting up.
	Slow flashing (at 0.5 Hz)	The network is unreachable.
	Flashing twice in succession	Possible cases: 1. Restoring the access point to factory settings. 2. Upgrading the firmware. 3. Handling alarms automatically. Note: Do not power off the access point in this case.
	Solid on	The access point is functioning properly.

	Off	The access point is not receiving power.
LAN Port Status LED (Green)	Flashing	The port has made a successful link and is sending/receiving traffic.
	Solid on	The port has made a successful link and is not sending/receiving traffic.
	Off	No link is detected for the port.
SFP Port Status LED (Green)	Flashing	The port has made a successful link and is sending/receiving traffic.
	Solid on	The port has made a successful link and is not sending/receiving traffic.
	Off	No link is detected for the port.
Reset Hole	Stick the pin into the Reset hole.	Restart the access point.
	Press and hold the pin to the reset hole for more than 5 seconds.	Restore the access point to factory settings.

Connecting the Access Point to the Internet

Method 1

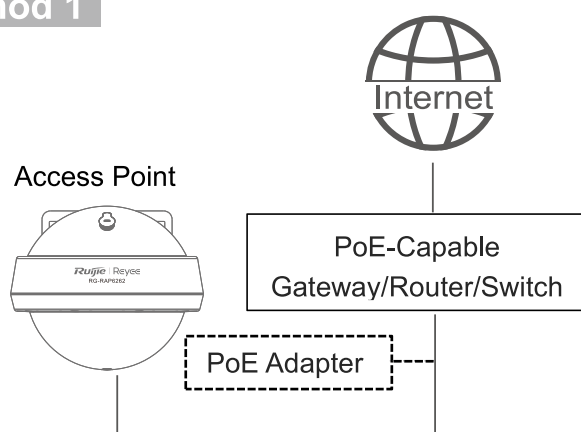

Method 2

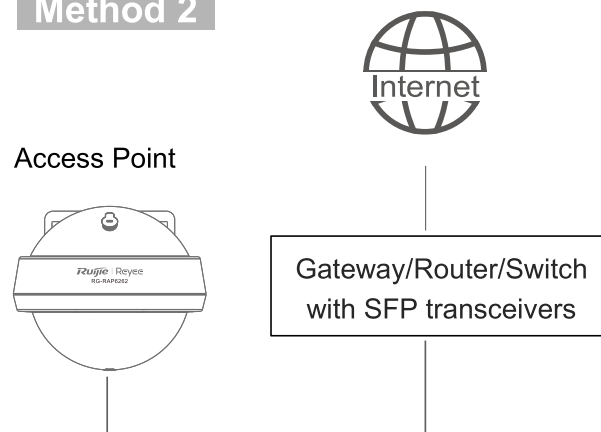

Note:

1. If the gateway or router or switch is not PoE-capable, an extra PoE power adapter or a DC power adapter (12 V/2 A) is needed.
2. The GE SFP transceiver for fiber connection is customer-supplied.
3. The access point can also be powered by a DC power adapter (12 V/2 A; inner diameter: 2.1 mm/0.08 in., outer diameter: 5.5 mm/0.22 in., depth: 9 mm/0.35 in.). The adapter should be purchased separately.

Mounting the Access Point

Note: Install the access point in a horizontal orientation.

Wall Mount

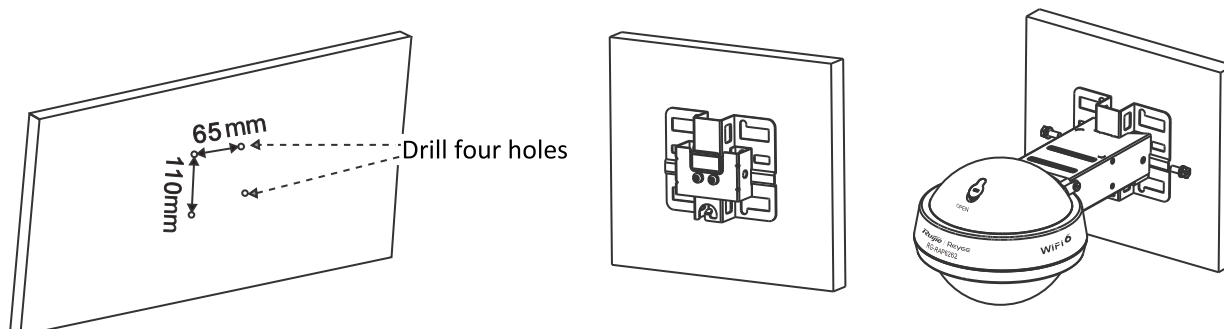

- (1) Drill four holes with the hole pattern of 65 mm x 110 mm (2.56 in. x 4.33 in.) on the wall.
- (2) Secure the mounting plate on the wall using M8 x 60 expansion anchors.
- (3) Install the access point and the mounting arm to the mounting plate using M8 x 20 screws.

Vertical Pole Mount

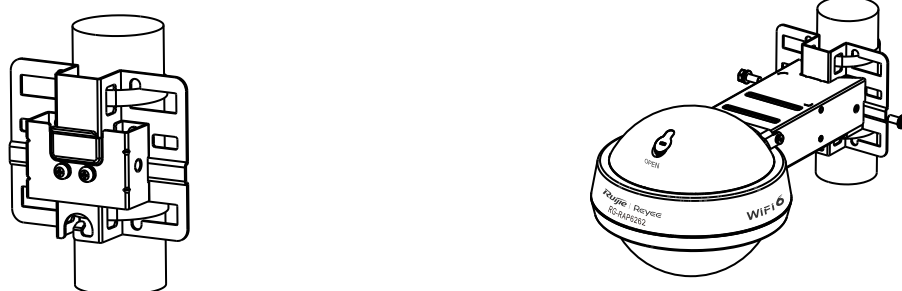

- (1) Secure the mounting plate to a vertical pole by threading two hose clamps through the square holes of the mounting plate. Tighten the screws using a Philips screwdriver.
- (2) Install the access point and the mounting arm to the mounting plate using M8 x 20 screws.

Horizontal Pole Mount



- (1) Secure the mounting plate to a horizontal pole by threading two hose clamps through the square holes of the mounting plate. Tighten the screws using a Philips screwdriver.
- (2) Install the access point and the mounting arm to the mounting plate using M8 x 20 screws.

Installing the Cables

Installing the Ethernet Cable

- (1) Trim an Ethernet cable according to the distance between the access point and the power supply.
- (2) Insert the unterminated end of the Ethernet cable through part D, C and B in sequence.

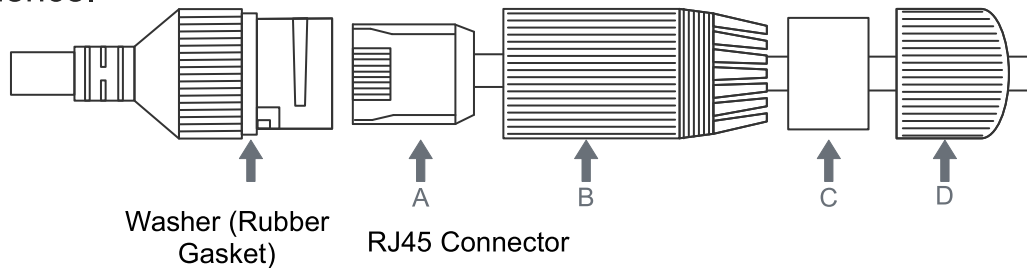

- (3) Install an RJ45 connector on the unterminated end of the Ethernet cable using an Ethernet cable installation tool.
- (4) Insert the RJ45 connector into the LAN/PoE port of the access point, and tighten part B, C and D in sequence.

Installing the Fiber-Optic Cable

- (1) Use a flat-blade screwdriver or a crowbar to remove the rubber plug. Then use a 5 mm Allen key to loosen the screw on the top cover of the access point.

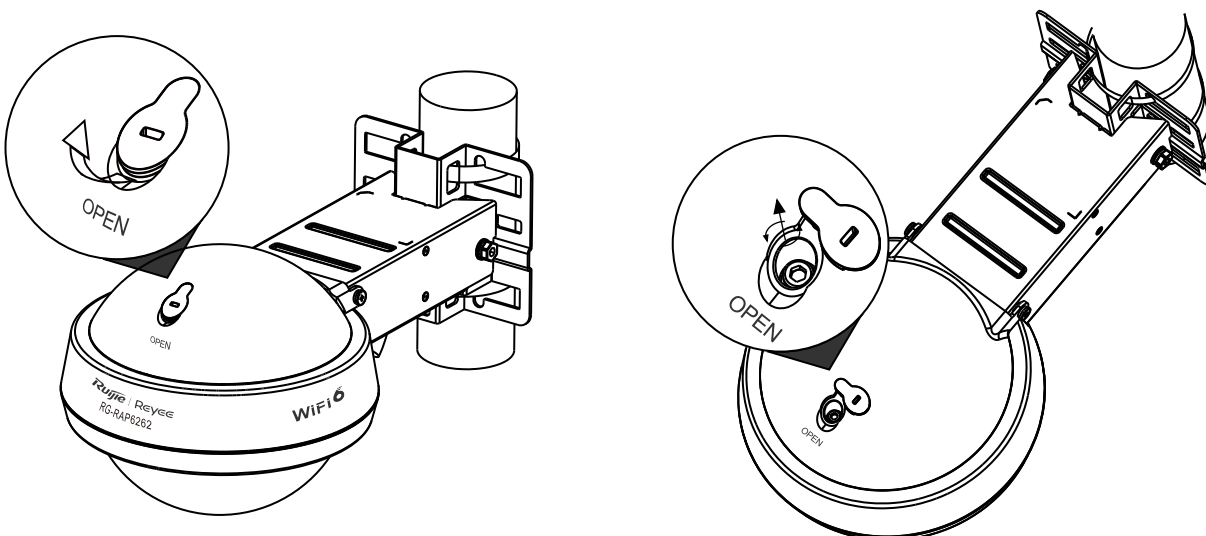

(2) Open the top cover and use the 5 mm Allen key to loosen the screw on the hinge pin. Remove the cables from the trough of the mounting arm and rotate the main unit by 90 degrees clockwise. Use the flat-blade screwdriver to loosen the SFP port plug and insert a SFP transceiver (customer-supplied) into the port.

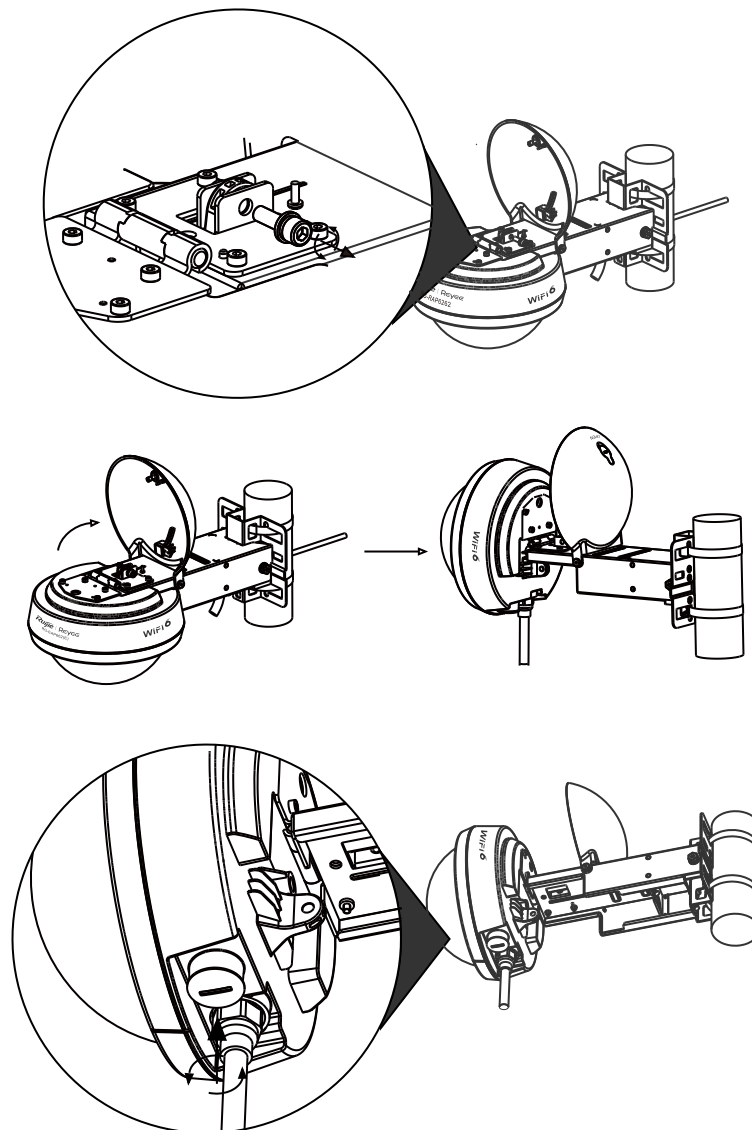

(3) A cable gland assembly includes four components: A (adapter base), B (split gasket), C (grommet), D (compression cap). Insert the unterminated end of a fiber-optic cable through part D, C, B and A in sequence. Install an RJ-45 connector on the unterminated end of the fiber-optic cable. Carefully insert the RJ-45 connector into the SFP port of the access point. Thread A (adapter base) into the SFP port. Slide B (split gasket) and C (grommet) along the cable, pressing firmly to seat B (gasket) completely into C (grommet). Tighten D (compression cap) until C (grommet) and B (gasket) compress on to the cable

and provide cable strain relief. Use a waterproof tape to tighten the cable gland.

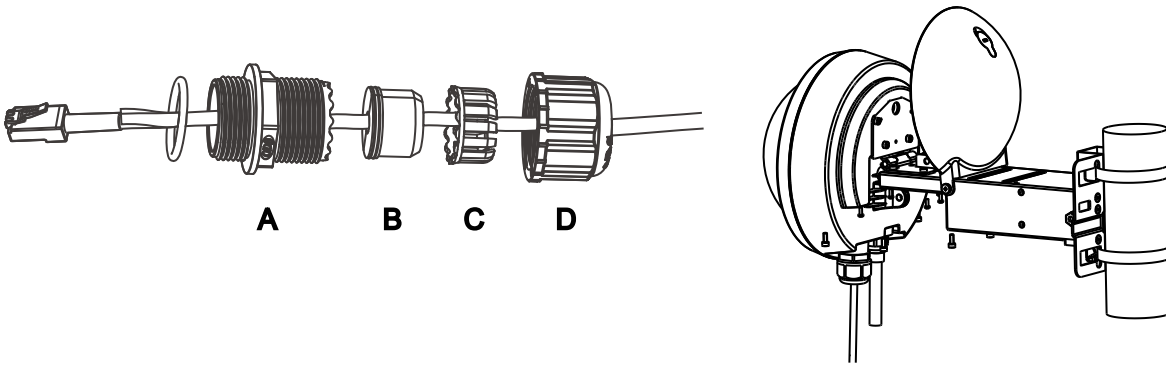

Note:

1. The waterproof tape and SFP transceiver are customer-supplied.
2. If you want to use an SFP transceiver (customer-supplied), the cable gland can only hold the LC to LC fiber-optic cable with a diameter ranging from 2.8 mm to 3.2 mm (0.11 in. to 0.13 in.).
3. When removing the cable gland, proceed in the reverse order of the installation. Start by loosening D (compression cap). Otherwise, the Ethernet cable may be damaged.

(4) Rotate the main unit by 90 degrees counterclockwise to remain horizontal with the ground. Tighten the screw on the hinge pin with the 5 mm Allen key.

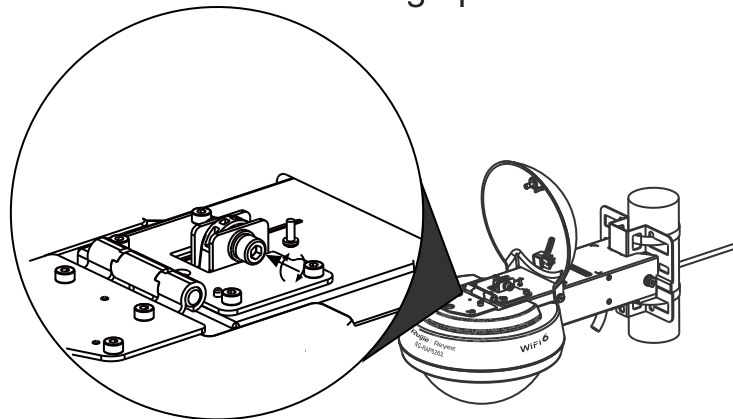

(5) Close the top cover and use the 5 mm Allen key to tighten the screw. Install the rubber plug in the hole.

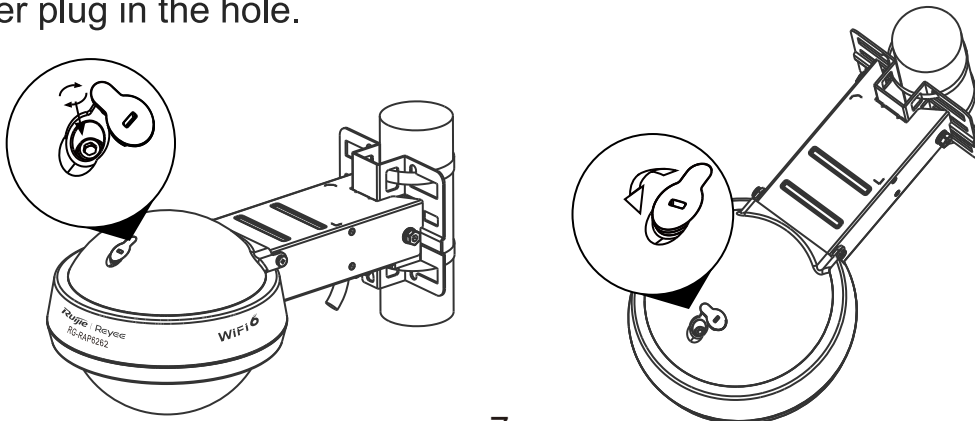

Installing the Cover on the Mounting Arm

(1) Make sure to seal the DC connector not in use and the reset hole with clean weatherproof caps (a). If you want to install the cable gland without an Ethernet cable threaded through it, insert the waterproof rubber rod (b) into the washer (rubber gasket), and tighten all parts properly.

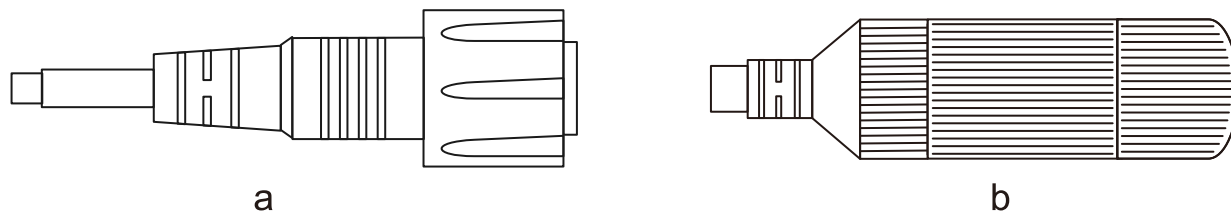

(2) Insert the caps and rubber rod into the trough of the mounting arm.

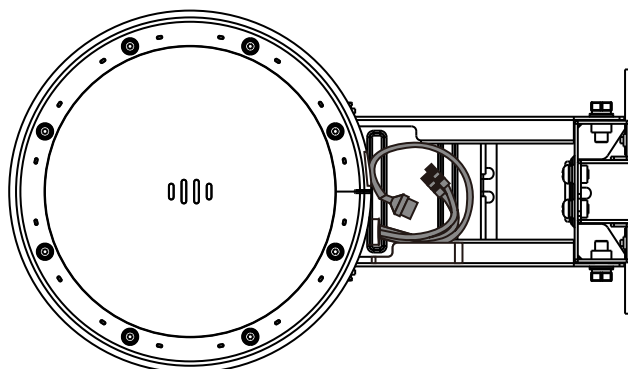

(3) Keep the cables organized. Press the cover toward the mounting arm until the retention clips on the cover lock over the mounting arm.

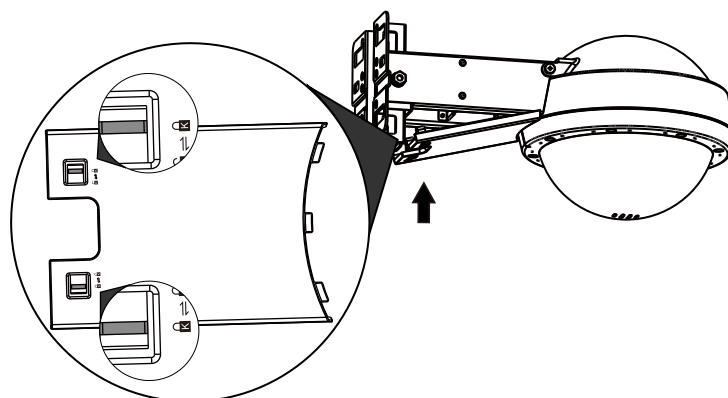

Note: To avoid damage to the cover of the mounting arm, hold the retention clips on the cover open to remove the cover.

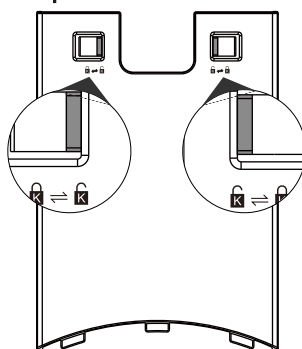

Configuring the Access Point

Method 1 (Recommended)

Scan the QR-code in the manual or on the device to download Ruijie Reyee App. Find **First time use Reyee Cloud?** and follow the guide on the App to configure the network.



Method 2

1. Connect the access point to the SSID. If multiple devices exist in the network, use SSID @Ruijie-mXXXX. If only one device exists in the network, use SSID @Ruijie-sXXXX. You can also create a wired connection by connecting your PC to the Ethernet port of the access point with an Ethernet cable.
2. If there is only one Reyee device in the network, access <http://192.168.120.1> via the browser. Otherwise, access <http://10.44.77.253>. In the latter case, configure your phone or PC with an IP address in the same network segment as 10.44.77.253, for example, 10.44.77.250.
3. Click **Start Setup** to create network projects.