

Lysora LCS-8GS-P Switch

Installation Guide

Copyright

Copyright © 2025 Lysora Technology Inc.

All rights are reserved in this document and this statement.

Without the prior written consent of Lysora Technology Inc., any organization or individual shall not reproduce, extract, back up, modify, or propagate the content of this document in any manner or in any form, or translate it into other languages or use some or all parts of the document for commercial purposes.

The  logo is the trademark of Lysora Technology Inc.

All other trademarks or registered trademarks mentioned in this document are owned by their respective owners.

Disclaimer

The products, services, or features you purchase are subject to commercial contracts and terms. Availability may vary by jurisdiction or contract, and some or all of the products, services, or features described in this document may not be available for you to purchase or use. **Except as expressly provided in a written agreement between you and Lysora Technology Inc., all representations and warranties, regarding the content of this document, to the maximum extent permitted by applicable law – including implied warranties of merchantability, fitness for a particular purpose, and non-infringement—are hereby disclaimed.**

The names, links, descriptions, screenshots, and any other information regarding third-party software mentioned in this document are provided for informational purposes only. **Lysora Technology Inc. does not endorse, recommend, guarantee, or assume liability for such third-party software's functionality, security, legality, accuracy, or fitness.** You are solely responsible for: (a) evaluating and selecting any third-party software based on your specific business requirements; (b) ensuring you have obtained all necessary licenses and authorizations for its use; and (c) assuming all risks associated with its use. **Lysora Technology Inc. shall have no liability for any claims or damages arising from your use of or reliance upon any third-party software.**

Lysora Technology Inc. reserves the right, at its sole discretion and without prior notice, to modify the content of this document at any time. These modifications may occur due to product updates, corrections, regulatory changes, or other reasons. **Lysora Technology Inc. undertakes no obligation to update or notify users of changes to this document.**

This document is provided “AS IS” and for general informational and guidance purposes only. While Lysora Technology Inc. strives to ensure the accuracy and reliability of the content at the time of publication, **it makes no warranty, express or implied, that the content is error-free, complete, or current.** All information contained herein is provided without any

warranty of merchantability, fitness for a particular purpose, or non-infringement. **You assume all risk for the use or application of this information.** For regulatory compliance queries (e.g., FCC/CPSC standards), please contact our support channel.

Preface

Intended Audience

This document is intended for:

- Network engineers
- Technical support and servicing engineers
- Network administrators

Technical Support

- Official website: <https://help.lysoratech.com/>
- Technical support email: support@lysoratech.com

Conventions

1. Symbols

The symbols that may be found in this document are described as follows:

Danger

An alert that calls attention to critical guidelines which, if not understood or followed, can result in personal injury.

Warning

An alert that calls attention to important information which, if not understood or followed, can result in data loss or equipment damage.

Caution

An alert that calls attention to essential information which, if not understood or followed, can result in functional failure or performance degradation.

Note

An alert that indicates additional or supplementary information.

Specification

An alert that indicates a description of product or version support.

2. Notes

This document provides installation steps, troubleshooting, technical specifications, and usage guidelines about cables and connectors. It is intended for users who want to understand the above and have extensive experience in network deployment and management, and assume that users are familiar with related terms and concepts.

Contents

Preface	i
1 Overview	1
1.1 Product Appearance	1
1.1.1 Front Panel	1
1.1.2 Rear Panel	2
1.1.3 LEDs	4
1.2 Technical Specifications	5
1.3 Cooling	7
2 Preparing for Installation	9
2.1 Package Contents	9
2.2 Safety Guidelines	9
2.2.1 General Precautions	9
2.2.2 Chassis-Lifting Guidelines	10
2.2.3 Electric Safety	10
2.2.4 Preventing ESD Damage	11
2.2.5 Laser Safety	11
2.3 Site Requirements	12
2.3.1 Ventilation and Cooling Requirements	12
2.3.2 Temperature and Humidity	12
2.3.3 Cleanliness	13
2.3.4 Anti-interference	14
2.3.5 Grounding	14
2.3.6 EMI Requirements	15

2.4 Tools	16
3 Product Installation	17
3.1 Before You Begin	17
3.2 Precautions.....	17
3.3 Installing the Switch.....	18
3.3.1 Mounting the Switch on the Wall.....	18
3.3.2 Mounting the Switch on a Workbench.....	19
3.4 Grounding the Equipment.....	20
3.5 Connecting Cables	20
3.6 Checklist After Installation	21
4 Networking Configuration	22
4.1 Setting Up the Configuration Environment.....	22
4.2 Power-on	22
4.3 Configuring the Switch through Web Login.....	23
5 Troubleshooting	24
5.1 Troubleshooting Flowchart	24
5.2 Common Troubleshooting	25
6 Appendix	27
6.1 Connectors and Media	27
6.1.1 10/100/1000BASE-T Ports.....	27
6.1.2 Optical Cable Connection.....	28
6.2 SFP Transceivers	29
6.3 Surge Protection.....	33
6.3.1 Installing an AC Power Lightning Arrester.....	33

6.3.2	Installing an Ethernet Port Lightning Arrester	35
6.4	Recommended Cabling	36
6.4.1	Requirements for the Minimum Bend Radius of an Ethernet Cable.....	36
6.4.2	Requirement for the Minimum Bend Radius of an Optical Cable	37
6.4.3	Precautions for Bundling up Cables.....	37

1 Overview

The LCS-8GS-P switch features nine 10/100/1000BASE-T ports (with ports 1 to 8 supporting PoE/PoE+), and one 1GE combo port on the front panel. The device also has one LED mode switch, one grounding stud, one reset button, one 54 V DC power input port, and one Kensington lock on the rear panel.

1.1 Product Appearance

Figure 1-1 Appearance of LCS-8GS-P



1.1.1 Front Panel

Figure 1-2 Front Panel of LCS-8GS-P

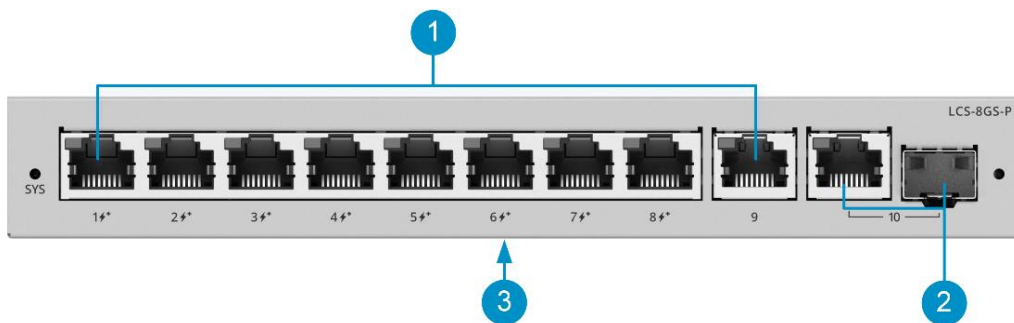

i Note

⚡+ indicates PoE+ port, which is compliant with IEEE 802.3af and IEEE 802.3at.

Table 1-1 Components on the Front Panel

No.	Silkscreen	Component	Description
1	1-9	10/100/1000BASE-T ports (1-9)	9 x 10/100/1000BASE-T ports with the auto MDI/MDIX crossover feature. Ports 1-8 support PoE/PoE+.
2	10	1GE combo port	<ul style="list-style-type: none"> • RJ45 port: 10/100/1000BASE-T port • Optical port: 1GE SFP port
3	-	Nameplate	The nameplate is located at the bottom of the switch.

Note

The combo port works in auto-negotiation mode by default (automatically adjusting the port type based on the access status). When both an optical port and an RJ45 port are connected, the optical port is preferred. To set the combo port to a fixed type, perform configuration on the web management page of the device.

1.1.2 Rear Panel

Figure 1-3 Rear Panel of LCS-8GS-P

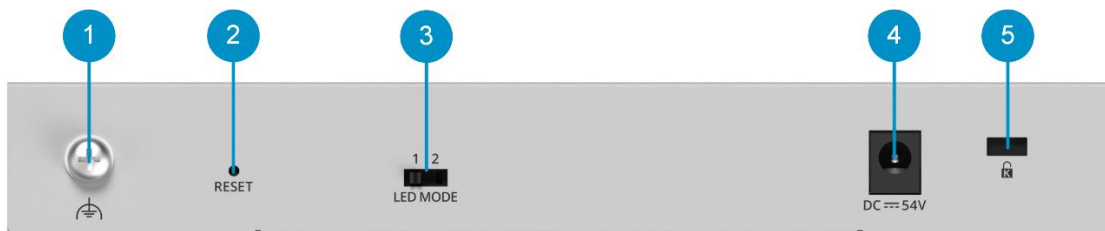

Table 1-2 Components on the Rear Panel

No.	Silkscreen	Component	Description
1	-	Grounding stud	For connecting to a grounding wire.
2	RESET	Reset button	<ul style="list-style-type: none"> • Press and hold the button for less than 2s: Restart the switch.

No.	Silkscreen	Component	Description
			<ul style="list-style-type: none"> ● Press and hold the button for more than 5s: Press and hold the button for more than 5s until the system status LED starts blinking to restore factory settings and restart the switch. ● Press and hold for 2s to 5s: No action is triggered.
3	LED MODE	Port LED switch	<ul style="list-style-type: none"> ● LED switch toggled to left (Mode 1): the port LED status indicates the status of traffic transmission. Solid green means that the port is link up, while blinking green means that the port is transmitting and receiving data. ● LED switch toggled to right (Mode 2): The port LED status indicates the PoE status. Solid green means that the port is supplying power, while blinking green means that the port is in power overload state.
4	DC=54 V	DC input	<ul style="list-style-type: none"> ● It is connected to a 54 V DC power source to supply power to the switch. ● The matching DC power connector has an outer diameter of 5.5 mm (0.22 in.), an inner diameter of 2.1 mm (0.08 in.), and a depth of 10 mm (0.39 in.).
5	-	Kensington lock	Used to lock the device to a fixed object, ensuring device asset security.

1.1.3 LEDs

Figure 1-4 LEDs of LCS-8GS-P

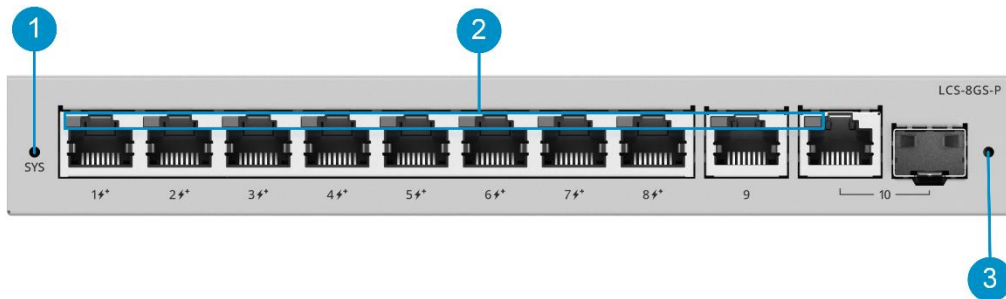

Table 1-3 LEDs

No.	Silkscreen	Component	Description
1	SYS	System status LED	<ul style="list-style-type: none"> ● Off: The switch is not powered on. ● Blinking green: If the power of PoE exceeds 120 W, the newly connected PD cannot be powered up because of insufficient power, but the switching function will operate properly. ● Solid green: System is operating normally.
2	-	10/100/1000BASE-T port status LED	<p>The LEDs of ports 1–8 can operate in either switching mode or PoE mode, while the LEDs of ports 9 and 10 can only operate in switching mode.</p> <ul style="list-style-type: none"> ● Switching mode (LED MODE 1): <ul style="list-style-type: none"> ○ Off: The port is not connected. ○ Solid green: The port is operating at 10/100/1000 Mbps, but is not receiving or sending data. ○ Blinking green: The port is operating at 10/100/1000 Mbps, and is receiving or sending data. ● PoE mode (LED MODE 2): <ul style="list-style-type: none"> ○ Off: PoE is disabled. ○ Solid green: PoE is enabled.

No.	Silkscreen	Component	Description
			<ul style="list-style-type: none"> ○ Blinking green: PoE overload occurs.
3	-	SFP port status LED	<ul style="list-style-type: none"> ● Off: The port is not connected. ● Solid green: The port is operating at 1000 Mbps, but is not receiving or sending data. ● Blinking green: The port is operating at 1000 Mbps, and is receiving or sending data.

1.2 Technical Specifications

Table 1-4 Technical Specifications

Parameter Type	Parameter Name	LCS-8GS-P
System Specifications	Flash memory	4 MB
	Forwarding rate	14.88 Mpps
	Switching capacity	20 Gbps(bit/s)
Port Specifications	Total number of RJ45 ports	10
	Total number of optical ports	1
	Number of 1GE combo ports	1
	Number of 1GE SFP ports	1
	Number of 10/100/1000BASE-T ports	10
	Reset button	1
	DIP switch	<p>LED mode switch toggled to left (Mode 1): The port LED status indicates the status of traffic transmission. Solid green means that the port is link up, while blinking green means that the port is transmitting and receiving data.</p> <p>LED mode switch toggled to right (Mode 2): The port LED status indicates the PoE status. Solid green means that the port is supplying power, while blinking green means that the port is in power overload state.</p>

Parameter Type	Parameter Name	LCS-8GS-P
	Optical Transceiver Type	See Appendix 6.2. SFP Transceivers are not supported. The transceiver types may update without prior notification. Please contact Lysora for details.
Power Supply and Consumption	PoE Out standard	PoE/PoE+ (IEEE 802.3af/at)
	Number of PoE/PoE+ Out ports	8
	PoE budget per port	30 W
	PoE budget	120 W
	PoE power pins	1–2 (+), 3–6 (-)
	Power input	DC adapter: <ul style="list-style-type: none"> Rated input voltage: 100 V AC to 240 V AC, 50 Hz to 60 Hz Maximum input voltage: 90 V AC to 264 V AC, 47 Hz to 63 Hz Rated input current: 2.5 A Output: <ul style="list-style-type: none"> Rated output voltage: 54 V DC Maximum output current: 2.4 A
	Maximum power consumption	<ul style="list-style-type: none"> 10 W (with no PoE load) 130 W (with PoE full load)
	Dimensions of the DC connector	<ul style="list-style-type: none"> Outer diameter: 5.5 mm (0.22 in.) Inner diameter: 2.1 mm (0.08 in.) Depth: 10 mm (0.39 in.)
Dimensions and Weight	Enclosure Material	Metal
	Product dimensions (W x D x H)	202 mm x 108 mm x 28 mm (7.95 in. x 4.25 in. x 1.10 in.)
	Weight	<ul style="list-style-type: none"> 0.55 kg (1.21 lbs) (without packaging materials) 1.65 kg (3.64 lbs) (with packaging materials)
Environment and Reliability	Fan	Fanless design
	Cooling	Natural cooling

Parameter Type	Parameter Name	LCS-8GS-P
	Mounting options	Wall/Desk
	Hot swapping of cables	Hot swapping supported by the service port and power connector
	MTBF	200,000 hours
	Operating temperature	0°C to 40°C (32°F to 104°F)
	Storage temperature	-40°C to +70°C (-40°F to +158°F)
	Operating humidity	10% RH to 90% RH (non-condensing)
	Storage humidity	5% RH to 95% RH (non-condensing)
	Altitude	-500 m to +5,000 m (-1,640.42 ft. to +16,404.20 ft.)
	ESD protection	<ul style="list-style-type: none"> Air discharge: 8 kV Contact discharge: 6 kV
	Surge protection	Service port: ±6 kV for common mode Power connector: ±4 kV for common mode and ±2 kV for differential mode
Certification and Regulatory Compliance	EMC	FCC 47 CFR Part 15 Subpart B ICES-003 Issue 7
	Safety compliance	UL 62368-1:2019
	Certification	FCC, IC, cTUVus
Interface	EEE	Yes

 **Warning**

The power adapter cannot be repaired. Do not disassemble it, as this may create a risk of electric shock.

 **Caution**

Operation of this equipment in a residential environment could cause radio interference.

1.3 Cooling

LCS-8GS-P adopts natural cooling. To ensure that the switch works properly in the specified environment, a minimum clearance of 100 mm (3.94 in.) must be maintained around the

device to ensure proper ventilation. Dust the device every three months to avoid blocking the ventilation openings on the housing.

2 Preparing for Installation

2.1 Package Contents

Table 2-1 LCS-8GS-P Package Contents

No.	Item	Quantity
1	Switch	1
2	Power adapter	1
3	User Manual	1
4	Power cord	1
5	Warranty card	1

Note

The package contents above are intended to provide a general overview, and are subject to the terms of the order contract. Please check your goods carefully against the package contents or order contract. If you have any questions, please contact the distributor.

2.2 Safety Guidelines

Caution

- To avoid personal injury or equipment damage, review the safety guidelines in this chapter before you begin the installation.
 - The following safety guidelines may not include all the potentially hazardous situations.
-

2.2.1 General Precautions

- Never operate the equipment in a wet environment, and avoid any liquids inside it. Keep the chassis clean and dust-free.
- Keep the equipment away from heat sources.
- Keep the equipment away from walk areas.

2.2.2 Chassis-Lifting Guidelines

- Avoid handling the device frequently.
- Keep balance and prevent personal injuries when handling the device.
- Turn off all power supplies and disconnect all cables before lifting or moving the equipment.

2.2.3 Electric Safety

Warning

- Any deviation from standard or improper electrical operations can result in accidents such as fires or electric shocks, potentially causing severe or even fatal harm to both individuals and equipment.
 - Direct or indirect touch through a wet object on high-voltage and mains supply can bring a fatal danger.
-
- Always observe the local regulations and standards. Only qualified personnel should be allowed to operate the equipment.
 - Carefully check the work area for potential hazards, including ungrounded power system, absent safety grounds, and damp floors.
 - Locate the emergency power-off switch in the room before installation. In the case of an accident, cut off the power supply immediately.
 - Never assume that power is disconnected from a circuit. Always check.
 - Select the right leakage protector (also called “leakage current switch” or “leakage current breaker”) for the power supply system. This equipment automatically disconnects the power supply in the event of leakage and the risk of electric shock. A leakage protector should meet the following requirements:

- The rated leakage action current of each leakage protector is greater than twice the theoretical maximum leakage current of all the power supplies in the system.

For example, if a system is equipped with 16 identical power supplies, and the leakage current of each power supply is equal to or less than 3.5 mA, then the leakage current of the system totals 56 mA. A leakage protector with a rated leakage action current of 30 mA supports no more than four power supplies (that is, action current of the leakage protector/2/Maximum leakage current of each power supply = $30/2/3.5 \approx 4.28$). In this case, 16 power supplies in the system require at least four leakage protectors with a rated action current of 30 mA, with each leakage protector supporting four power supplies.

Although the number of power supplies in a system differs in models, the rated leakage action current of each leakage protector divided by two must be greater than the sum of the maximum leakage current of all the power supplies.

- The rated leakage non-action current of a leakage protector should be 50% of the leakage action current. If the non-action current value is too small, the high sensitivity level can cause the circuit to break, leading to power cutoff and service interruption, even if the leakage current value is normal.

For example, if a leakage protector has a rated leakage action current of 30 mA, the rated leakage non-action current should be 15 mA. The leakage protector will not activate unless the leakage current exceeds 15 mA.

⚠ Caution

To ensure personal safety, each leakage protector in the system must have a rated leakage action current equal to or below 30 mA, which is the recognized safety threshold for human body current. If the total leakage current of the system exceeds twice the 30 mA limit, the system must be equipped with two or more leakage protectors to maintain safety.

2.2.4 Preventing ESD Damage

To prevent damage caused by static electricity, you must pay attention to the following:

- Ensure that the grounding screw on the rear panel of the device is tightened.
- Keep the site as dust free as possible.
- Maintain appropriate humidity conditions.
- Before installing any pluggable modules, wear an anti-ESD wrist strap and make sure that it is properly grounded.
- Avoid contact between the printed circuit boards and clothing. The anti-ESD wrist strap only protects the printed circuit boards from ESD voltages on the body. ESD voltages on clothing can still cause damage.

2.2.5 Laser Safety

The equipment supports various types of optical transceivers, which are Class I laser products.

- When an optical transceiver is working, ensure that its port is connected to an optical cable or covered by a dust cap to keep out dust and prevent it from burning your eyes.
- Do not stare into an optical port.

Figure 2-1 Laser Product ID

⚠ Caution

Do not approach or stare into an optical port under any circumstances. This may cause permanent damage to your eyes.

2.3 Site Requirements

The equipment must be installed indoors for normal operation and prolonged service life.

The installation site must meet the following requirements.

2.3.1 Ventilation and Cooling Requirements

Maintain a minimum clearance of 100 mm (3.94 in.) around the switch for air circulation and ventilation. After various cables are connected, bundle the cables or place them in the patch panel to avoid blocking air inlets. Dust the device every three months to avoid blocking the ventilation openings on the housing.

2.3.2 Temperature and Humidity

To ensure the normal operation and a prolonged service life of the equipment, maintain an appropriate temperature and humidity in the installation environment.

Prolonged exposure to inappropriate temperature and humidity conditions can cause damage to the equipment.

- In an environment with high relative humidity, insulating materials are prone to poor insulation or even electricity leakage.
- In an environment with low relative humidity, insulating gaskets may shrink, resulting in screw loosening.
- In a dry environment, static electricity is more likely to occur, posing a risk to the internal circuits of equipment.
- A high temperature can accelerate the aging process of insulation materials, greatly reducing the availability of the equipment and severely affecting its service life.

Note

The operating temperature and humidity are measured at 1.5 m (4.92 ft.) above the floor and 0.4 m (1.31 ft.) before the rack when there is no protective plate in front or on the rear of the rack.

2.3.3 Cleanliness

Dust poses a significant hazard to the equipment. Dust on the enclosure causes electrostatic adhesion, leading to poor contact of the metallic joints. Electrostatic adhesion is more likely to occur in an indoor environment with relatively low humidity, not only affecting the service life of the equipment, but also causing communication faults. The following table lists the requirements for dust concentration and particle size in the equipment room.

Table 2-2 Requirements for Dust

Particle Diameter	Unit	Concentration
≥0.5 μm	Particles/m ³	≤ 3.5 × 10 ⁶
≥5 μm	Particles/m ³	≤ 3.5 × 10 ⁴

Apart from dust, there are also requirements on the salt, acid, and sulfide in the air of the equipment room. These harmful substances will accelerate metal corrosion and component aging. Therefore, the equipment room should be properly protected against harmful gases, such as sulfur dioxide, hydrogen sulfide, nitrogen dioxide, chlorine gas, and so on. The following table lists the limits on harmful gases.

Table 2-3 Requirements for Gases

Gas	Average (mg/m ³)	Maximum (mg/m ³)
Sulfur dioxide (SO ₂)	0.3	1.0
Hydrogen sulfide (H ₂ S)	0.1	0.5
Nitrogen dioxide (NO ₂)	0.5	1.0
Chlorine gas (Cl ₂)	0.1	0.3

Note

Average refers to the average value of harmful gases measured in a week. **Maximum** refers to the upper limit of harmful gases measured in a week for up to 30 minutes every day.

2.3.4 Anti-interference

The switch is susceptible to external interference by capacitive coupling, inductive coupling, electromagnetic waves, common impedance (ground) coupling, or conduction over power lines, signal lines and output lines. Note that:

- In a TN earthing system, use a 3-wire single-phase outlet that has a protective earth (PE) contact to allow the filter circuit in the device to eliminate interference from the power grid.
- The switch should be located far away from the large power radio launch pads, radar launch pads, and high-frequency large-current devices.
- Use EMI shielding such as shielded interface cables to minimize interference when necessary.
- Route interface cables only indoors to prevent signal ports from getting damaged by overvoltage or overcurrent caused by lightning strikes.

2.3.5 Grounding

A proper grounding system is the basis for stable and reliable running. It is indispensable for preventing lightning strikes and interference. Carefully check the grounding conditions at the installation site according to the grounding specifications, and complete grounding properly based on the actual situation.

Note

- Effective grounding of the switches is an important guarantee for lightning protection and interference prevention. Therefore, the switch must be properly grounded.
 - The grounding wire is customer supplied.
-

- **Secure Grounding**

Ensure that the rack and power distribution device are securely grounded when the switch uses the AC power supply. Otherwise, electric shock may occur when the insulation resistance between the power supply inside the switch and the chassis becomes small.

Note

- The building should provide a protective ground connection to ensure that the device is connected to a protective earth.
 - The O&M personnel should check whether the AC socket is reliably connected to the protective ground of the building. If not, the O&M personnel should use a protective earth conductor from the AC outlet protective earth terminal to the building protective earth.
 - The power socket should be installed near the device and easily accessible.
 - During the device installation, the ground connection must always be made first and disconnected last.
 - The cross-sectional area of the protective ground cable should be at least 0.75 mm² (18 AWG).
-

- **Lightning Grounding**

The lightning protection system of facilities is standalone, and is composed of a lightning rod, a down conductor, and a connector connected to the grounding system. The grounding system is usually used for power reference grounding and safe grounding of the rack. Lightning grounding is required only for facilities and is not required for the switch.

- **EMC Grounding**

Grounding required for electromagnetic compatibility includes shielded grounding, filter grounding, noise and interference suppression, and level reference, which contribute to the overall grounding requirements. The resistance of the grounding cable should be smaller than 1 ohm.

2.3.6 EMI Requirements

All electromagnetic interference (EMI) sources, either from outside or inside of the device or application system, affect the device by capacitive coupling, inductive coupling, or electromagnetic waves.

EMI occurs due to radiation or conduction, depending on the transmission path.

When the energy, often radio energy, from a component arrives at a sensitive component through space, the energy is known as radiated interference. The interference source can be both a part of the interfered system and a completely electrically isolated unit. Conducted interference occurs when interference is transferred from one unit to another through cables which are usually electromagnetic wires or signal cables connecting the source and the sensor. Conducted interference often affects the power supply of the switch, but this can be controlled by a filter. Radiated interference may affect any signal path in the equipment, and is difficult to shield.

- Interference prevention measures should be taken for the power supply system.

- Keep the grounding device of the switch far away from the grounding device and lightning grounding device of the power equipment.
- Keep the switch far away from the high-power radio transmitter, radar launch pad, and high-frequency large-current devices.
- Take electromagnetic shielding measures when necessary.

2.4 Tools

Table 2-4 Tools

Common Tools	Phillips screwdriver, slotted screwdriver, related copper and fiber-optic cables, bolts, diagonal pliers, cable ties
Special Tools	ESD tools
Meters	Multimeter
Relevant Equipment	PC, display, and keyboard

Note

The LCS-8GS-P switch is delivered without a tool kit. Customers need to get ready the tools.

3 Product Installation

Note

- Before reading chapter 3 "Product Installation", ensure that you have read chapter 2 carefully.
 - Verify that requirements described in chapter 2 have been met.
-

3.1 Before You Begin

Confirm the following requirements before installation:

- The installation environment meets heat dissipation requirements.
- The installation environment meets the temperature and humidity requirements.
- The power supply and required current are available in the installation site.
- Ethernet cables have been deployed at the installation site.

3.2 Precautions

Pay attention to the following:

- Connect the power cords of different colors to the corresponding cable terminals.
- Ensure that the connector of the power cord is properly seated in the power port of the switch. After the power cord is securely inserted into the device, fasten the power cord with power cord retention clips.
- Do not place anything on the top of the switch.
- Maintain a minimum clearance of 100 mm (3.94 in.) around the device to ensure proper airflow. Do not stack switches.
- Keep the switch away from high-power radio launch pads, radar launch pads, and high-frequency large-current devices. Take electromagnetic shielding measures to minimize interference when necessary, for example, use shielded interface cables.
- Manage Ethernet cables with a distance of 100 meters (328.08 feet) indoors. Take lightning protection measures if they need to be routed outdoors.

3.3 Installing the Switch

3.3.1 Mounting the Switch on the Wall

Note

- The equipment can be mounted on a wall. Two M4 screws and two plastic expansion anchors must be prepared by yourself.
 - When the equipment is mounted on a wall, it is only suitable to be mounted on a concrete or non-flammable surface.
-

The steps for wall mounting a switch are as follows:

- (1) Drill two holes 112.6 mm (4.43 in.) apart at suitable positions on the wall. The hole diameter and depth depend on the specifications of the purchased plastic expansion anchors.
- (2) Insert two plastic expansion anchors into the drilled holes, and then screw two M4 screws into the plastic expansion anchors.
- (3) Mount the switch onto the M4 screws.

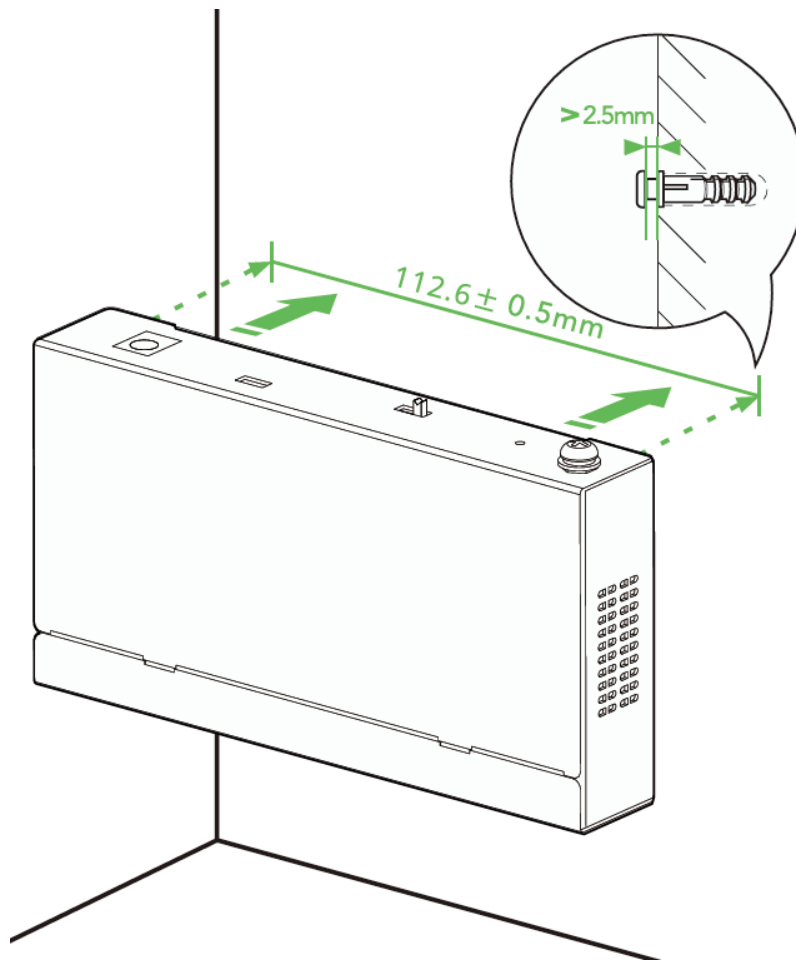
Figure 3-1 Wall Mounting the LCS-8GS-P

3.3.2 Mounting the Switch on a Workbench

Note

The switch must be installed in a location where movement is restricted.

If wall mounting a switch is not available, install it on a clean workbench.

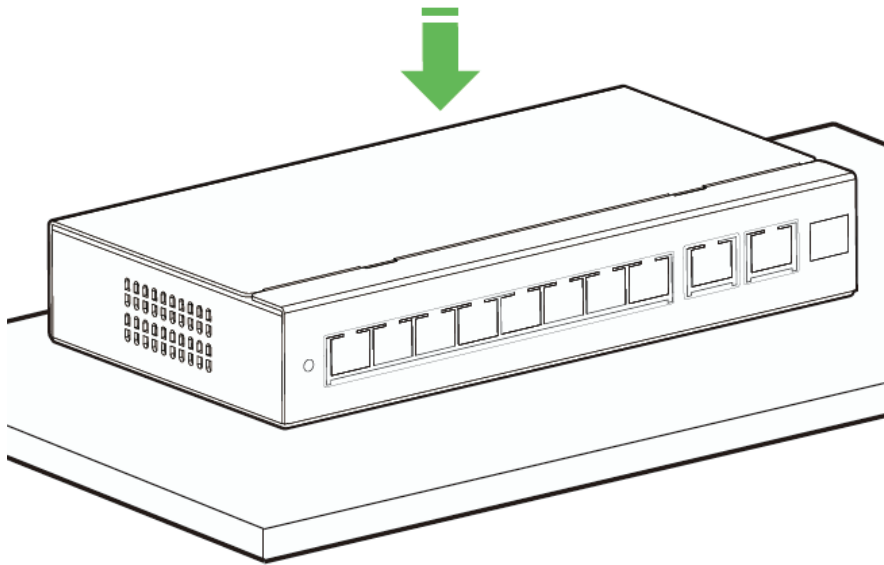
Figure 3-2 Mounting a Switch on a Workbench

3.4 Grounding the Equipment

Connect the grounding wire at the installation site to the grounding stud on the rear panel of a switch.

Note

The grounding wire is not delivered with the switch. Please purchase it based on actual requirements.

3.5 Connecting Cables

- (1) Connect the power adapter. Insert one end of the power adapter into the switch's power input port and the other end into the power strip. Before plugging in, ensure that the power strip is turned off.

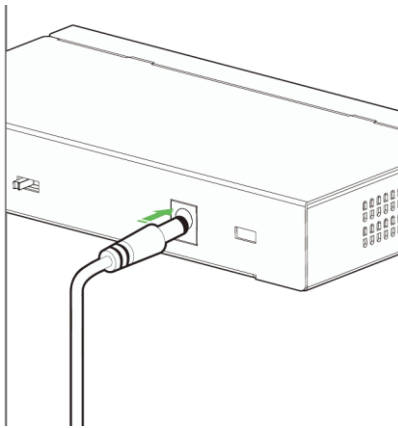
Figure 3-3 Connecting a Power Cord

- (2) Connect Ethernet cables. Connect one end of a CAT5e cable to the device's Ethernet port, and the other end to the downstream device.
- (3) Connect optical cables. Insert the optical transceivers into optical ports according to the panel identification. Then connect single-mode fibers (SMFs) and multimode fibers (MMFs) to the corresponding optical transceivers, during which the transmitting and receiving ends of the optical cables should be distinguished. For details, see [6.1.2](#).

3.6 Checklist After Installation

Caution

Please turn off the power to avoid personal injury and damage to components caused by incorrect connection.

- Verify that the grounding wire is connected.
- Verify that the Ethernet cables and power cord are properly connected.
- Check whether the Ethernet cables with a distance of 100 m (328.08 ft.) are routed indoors. If not, check whether the power strip with surge protection, Ethernet surge protector, and others are installed for the AC power supply.
- Verify that there is a minimum clearance of 10 cm (3.94 in.) around the switch.

4 Networking Configuration

4.1 Setting Up the Configuration Environment

Connect a PC to the switch's Ethernet port using an Ethernet cable.

Figure 4-1 Configuring Environment

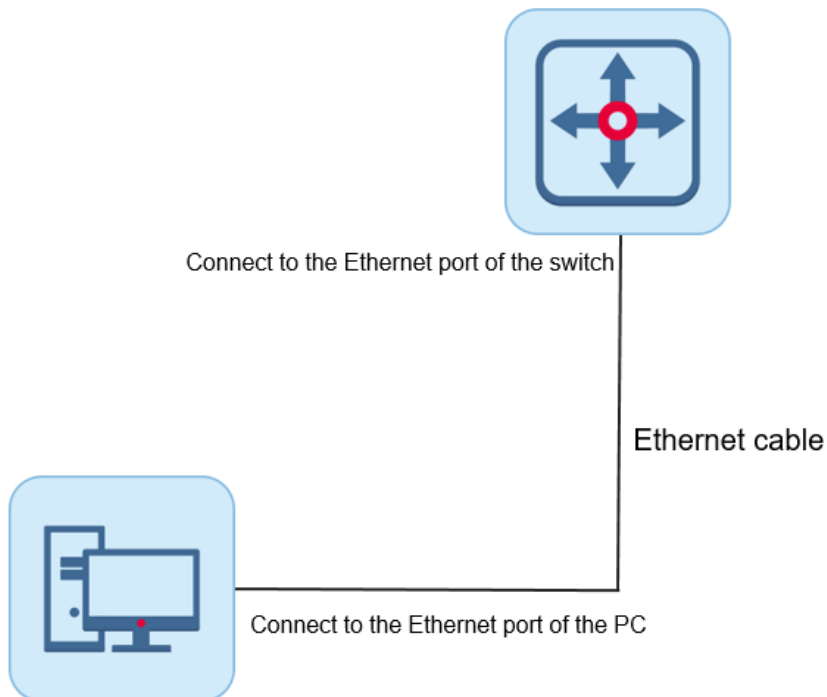

4.2 Power-on

(1) Check the items before power-on.

- The equipment is properly grounded.
- The power cord is reliably connected.
- The input voltage meets the requirement.
- The Ethernet cable is properly connected, and the client such as a PC used for configuration is already turned on.

(2) Power on the equipment.

(3) Check the items after power-on.

After the equipment is powered on, check the following items:

- The system status LED works properly.

- Service ports can forward data properly.

4.3 Configuring the Switch through Web Login

- (1) Set the IP address of the PC to 10.100.111.XXX (Range: 1–254, excluding 200).

Figure 4-2 Changing the PC's IP Address

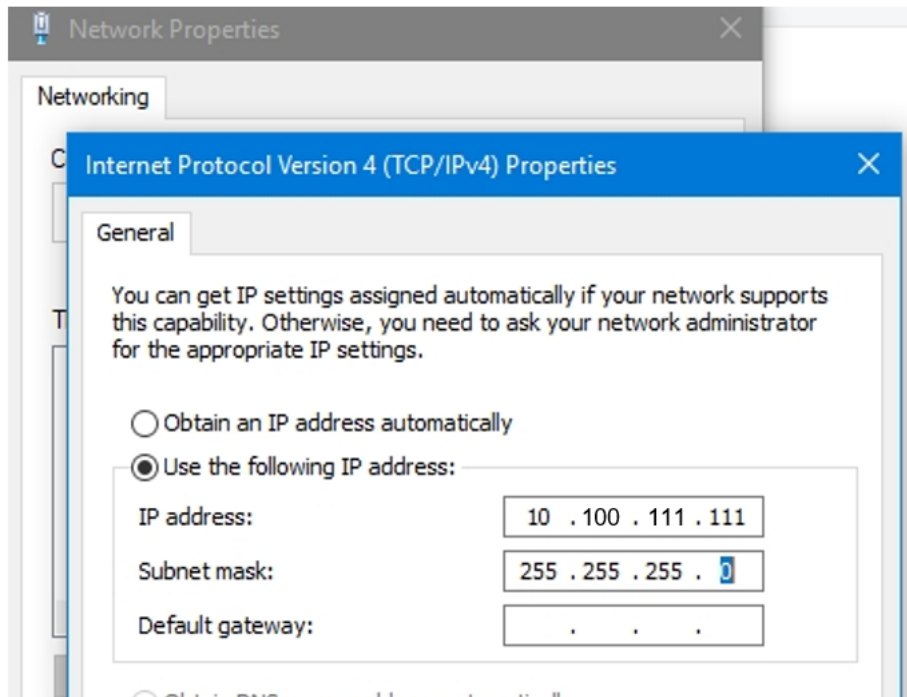

- (2) Open your browser, enter 10.100.111.200 in the address bar, and log in to the management system after setting a password.
- (3) Perform device commissioning and configuration based on service requirements.

Note

For security purposes, you are advised to change the password regularly.

5 Troubleshooting

5.1 Troubleshooting Flowchart

If the switch is not working properly after installation, you can refer to the following flowchart for troubleshooting.

Note

You can determine whether each checking item in the process is normal based on the information provided in the previous "Overview" and "Product Installation" sections.

Figure 5-1 General Troubleshooting Flowchart

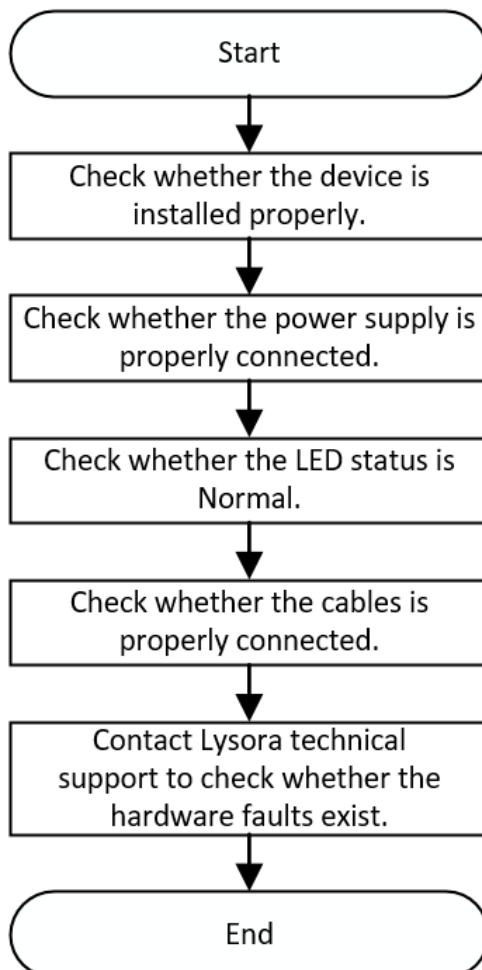

5.2 Common Troubleshooting

Fault Symptom	Possible Cause	Suggested Action
The system status LED is off after the switch is powered on.	No power is supplied to the switch or the power cord is loose.	Check whether the power socket in the equipment room is normal and whether the power cord connected to the switch is loose.
The Ethernet port is disconnected or an error occurs in the transmission and receiving of frames.	The twisted pair cable is not connected properly.	Replace the twisted pair cable.
	The cable length exceeds 100 m (328.08 ft.).	Use an optical cable for data transmission or connect to an intermediate switch for relay.
	The port is specially configured and does not use the same work mode as the interconnected switch.	Check whether the port is configured to work in the same mode as that of the interconnected switch.
An optical port is not reachable.	The transmit and received ends are connected incorrectly.	Exchange the transmit and received ends of the optical cable.
	The types of the interconnected optical transceivers do not match.	Replace the optical transceiver with another one of the same type.
	The optical cable type does not meet the requirements.	Replace the optical cable with a qualified one.
	The optical cable length is beyond the allowed length marked on the optical transceiver.	Use an optical cable with the required length.
	The optical cable or connector is contaminated.	Clean the connector with a lint-free cloth or a cleaning pen.
The Ethernet ports are transmitting and receiving frames normally, but their LEDs are off.	The LED mode toggle is incorrectly set. The LED mode toggle is set to LED mode 2. As a result, the Ethernet port LEDs display the	Set the LED mode toggle to LED mode 1 so that the Ethernet port LEDs display the data receiving and sending status.

Fault Symptom	Possible Cause	Suggested Action
	PoE status, but PoE is disabled on the ports.	

6 Appendix

Note

The appendix contains general information. Some items may not apply to this product and can be ignored.

6.1 Connectors and Media

6.1.1 10/100/1000BASE-T Ports

1000BASE-T/100BASE-TX/10BASE-T ports are Ethernet ports with auto-negotiation of three speeds: 10 Mbps, 100 Mbps, and 1000 Mbps. They support auto MDI/MDIX Crossover, and use RJ 45 connectors.

Compliant with the IEEE 802.3ab standard, a 1000BASE-T port requires 100-ohm Category 5 or 5e unshielded twisted pair (UTP) or shielded twisted pair (STP) (recommended) cables, and supports a maximum distance of 100 meters (328 feet).

A 1000BASE-T port requires all four pairs of wires to be connected for data transmission. [Figure 6-1](#) shows the four pairs of wires for the 1000BASE-T port.

Figure 6-1 1000BASE-T Twisted Pair Connections

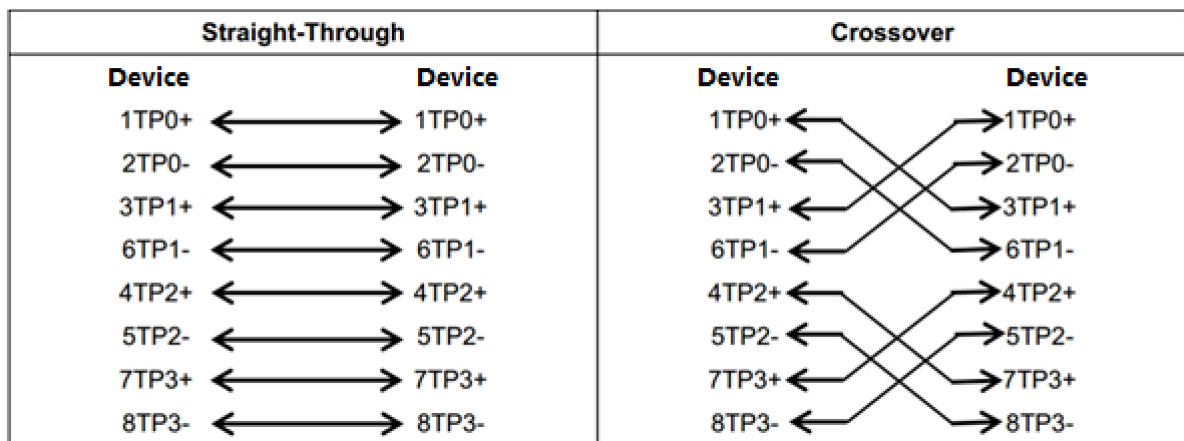

100BASE-TX/10BASE-T ports can be interconnected using cables of the preceding specifications. In addition, a 10BASE-T port can be connected using 100-ohm Category 3, Category 4, and Category 5 cables, while a 100BASE-TX port can be connected using 100-ohm Category 5 cables, and supports a maximum distance of 100 meters (328 feet). [Table 6-1](#) shows 100BASE-TX/10BASE-T pin assignments.

Table 6-1 100BASE-TX/10BASE-T Pin Assignments

Pin	Socket	Plug
1	Input Receive Data+	Output Transmit Data+
2	Input Receive Data-	Output Transmit Data-
3	Output Transmit Data+	Input Receive Data+
6	Output Transmit Data-	Input Receive Data-
4, 5, 7, 8	Not Used	Not Used

[Figure 6-2](#) shows the connection of straight-through and crossover cables for 100BASE-TX/10BASE-T ports.

Figure 6-2 100BASE-TX/10BASE-T Twisted Pair Connections

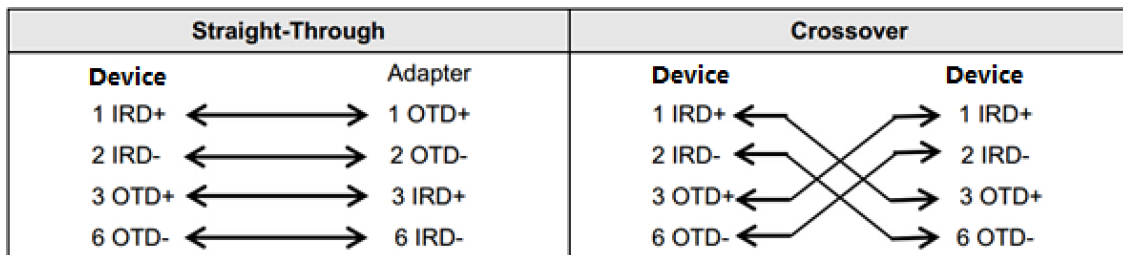

6.1.2 Optical Cable Connection

You can choose SMF or MMF optical cables based on the type of optical transceiver connected to the optical port. [Figure 6-3](#) shows the connection.

Figure 6-3 Connecting the Optical Cables

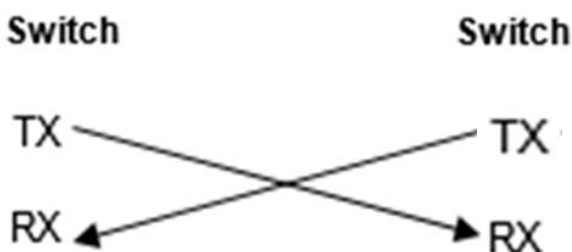

6.2 SFP Transceivers

We provide appropriate SFP transceivers based on port types. You can choose the one that best suits your needs. In addition to the following SFP optical transceivers, the MINI-GBIC-GT for photoelectric conversion is also supported. The following models and technical specifications of some SFP transceivers are listed for your reference.

Table 6-2 Technical Specifications of SFP Optical Transceivers

Model	Wavelength (nm)	Cable type	DDM (Yes/No)	Intensity of Transmitted Light (dBm)		Intensity of Received Light (dBm)	
				Min	Max	Min	Max
MINI-GBIC-SX-MM850	850	MMF	No	-9.5	-3	-17	0
MINI-GBIC-LX-SM1310	1310	SMF	No	-9.5	-3	-20	-3
GE-eSFP-SX-MM850	850	MMF	Yes	-9.5	-3	-17	0
GE-eSFP-LX-SM1310	1310	SMF	Yes	-9.5	-3	-20	-3
GE-SFP-LX-SM1310	1310	SMF	No	-9.5	-3	-20	-3
MINI-GBIC-LH40-SM1310	1310	SMF	Yes	-2	3	-22	-3
GE-SFP-SX-SM1310-BIDI	1310	MMF	No	-10	-5	-17	-3
GE-SFP-SX-SM1550-BIDI	1550	MMF	No	-10	-5	-17	-3
GE-SFP-LX20-SM1310-BIDI	1310TX/1550RX	SMF	Yes	-9	-3	-20	-3

Model	Wavelength (nm)	Cable type	DDM (Yes/No)	Intensity of Transmitted Light (dBm)		Intensity of Received Light (dBm)	
				Min	Max	Min	Max
GE-SFP-LX20-SM1550-BIDI	1550TX/1310RX	SMF	Yes	-9	-3	-20	-3
GE-SFP-LH40-SM1310-BIDI	1310TX/1550RX	SMF	Yes	-5	0	-24	-1
GE-SFP-LH40-SM1550-BIDI	1550TX/1310RX	SMF	Yes	-5	0	-24	-1
MINI-GBIC-ZX50-SM1550	1550	SMF	Yes	-5	0	-22	-3
MINI-GBIC-ZX80-SM1550	1550	SMF	Yes	0	4.7	-22	-3
MINI-GBIC-ZX100-SM1550	1550	SMF	Yes	0	5	-30	-9
GE-SFP-SX	850	MMF	No	-9.5	-3	-17	0
GE-SFP-LX	1310	SMF	No	-9.5	-3	-20	-3
SFP-MM850	850	MMF	No	-9.5	-3	-17	0
SFP-SM1310	1310	SMF	No	-9.5	-3	-20	-3

Table 6-3 1000BASE-T SFP Media Converter

Standard	Model	DDM Supported (Yes/No)
1000Base-T	Mini-GBIC-GT	No

Table 6-4 Cabling Specifications of SFP Optical Transceivers

Model	Connector Type	Cable type	Core Specifications (μm)	Max. Cabling Distance
MINI-GBIC-SX-MM850	L/C	MMF	62.5/125	275 m
			50/125	550 m
MINI-GBIC-LX-SM1310	L/C	SMF	9/125	10 km
GE-eSFP-SX-MM850	L/C	MMF	62.5/125	275 m
			50/125	550 m
GE-eSFP-LX-SM1310	L/C	SMF	9/125	10 km
GE-SFP-LX-SM1310	L/C	SMF	9/125	10 km
MINI-GBIC-LH40-SM1310	L/C	SMF	9/125	40 km
GE-SFP-SX-SM1310-BIDI	L/C	MMF	50/125	500 m
GE-SFP-SX-SM1550-BIDI	L/C	MMF	50/125	500 m
GE-SFP-LX20-SM1310-BIDI	L/C	SMF	9/125	20 km
GE-SFP-LX20-SM1550-BIDI	L/C	SMF	9/125	20 km
GE-SFP-LH40-SM1310-BIDI	L/C	SMF	9/125	40 km
GE-SFP-LH40-SM1550-BIDI	L/C	SMF	9/125	40 km
MINI-GBIC-ZX50-SM1550	L/C	SMF	9/125	50 km

Model	Connector Type	Cable type	Core Specifications (μm)	Max. Cabling Distance
MINI-GBIC-ZX80-SM1550	L/C	SMF	9/125	80 km
MINI-GBIC-ZX100-SM1550	L/C	SMF	9/125	100 km
GE-SFP-SX	L/C	MMF	62.5/125	275 m
			50/125	550 m
GE-SFP-LX	L/C	SMF	9/125	10 km
Mini-GBIC-GT	RJ45 Ethernet cable	Cat 5 (or higher) twisted-pair cable		100 m

Note

- For optical transceivers with a maximum cabling distance of over 40 km (including 40 km), install an optical attenuator to avoid overload when using short-distance SMFs.
- An optical module is a laser transmitter. Do not look directly into the optical module to prevent it from burning your eyes.
- To keep the optical module clean, ensure that the unused ports remain capped.
- No additional cable needs to be connected when an SFP cable is used. You need to only plug both ends of the SFP cable into the corresponding ports of the switch.

Table 6-5 Pairing of BiDi Optical Transceivers

Speed/Distance	Pairing Model
1000 Mbps/500 m	GE-SFP-SX-SM1310-BIDI GE-SFP-SX-SM1550-BIDI
1 Gbps/20 km	GE-SFP-LX20-SM1310-BIDI GE-SFP-LX20-SM1550-BIDI

Speed/Distance	Pairing Model
1 Gbps/40 km	GE-SFP-LH40-SM1310-BIDI
	GE-SFP-LH40-SM1550-BIDI

Note

The BIDI modules must be used in pairs. For example, if you install the GE-SFP-LX20-SM1310-BIDI in the local port, you must install the GE-SFP-LX20-SM1550-BIDI in the peer port.

6.3 Surge Protection

6.3.1 Installing an AC Power Lightning Arrester

When an AC power cord from outdoors is directly plugged into the power port of the equipment, the AC power connector must be connected to an external surge protector power strip to protect the equipment against lightning strikes. The surge protector power strip can be fixed on the rack, workbench, or wall in the equipment room by using cable ties and screws. AC power enters the equipment through the surge protector power strip.

Figure 6-4 Installing an AC Power Lightning Arrester

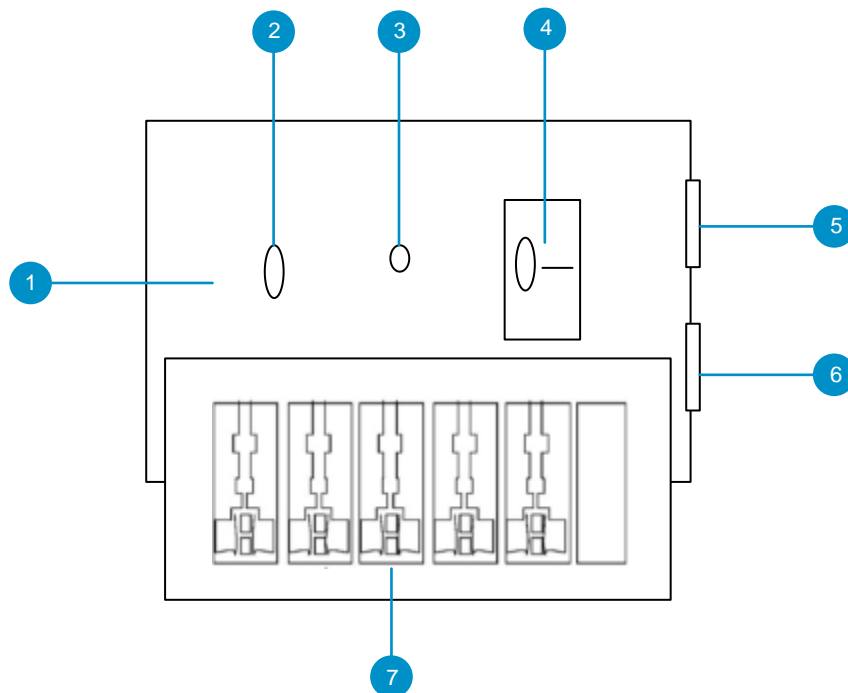

No.	Description
1	Installed electronic circuit board
2	Normally running indicator: When the indicator is green, the circuit is working properly. Otherwise, the protective circuit is damaged.
3	Grounding and polarity detection indicator: If the indicator is red, cable connection is incorrect (the ground cable is not connected, or the N and L lines are reversely connected). Check your power supply line.
4	Power switch
5	IEC standard socket, which is connected to the power supply in the equipment room through the power cable
6	Overload auto-protector, which can be reset manually
7	Multi-purpose sockets (connected to the power supply of the switch)

 Note

The lightning arrester is not delivered with the equipment. Please purchase it based on actual requirements.

Precautions:

- Make sure that the PE terminal of the power arrester is well grounded.
- After the AC power plug of the equipment is connected to the socket of the power arrester (lightning resistance socket), the surge protection function is implemented only if the RUN indicator is green and the ALARM indicator is OFF.
- If the indicator on the power arrester is red, check whether it is caused by poor grounding connection or by the reversed connection of the Neutral and Live lines. The detection method is as follows: Use a multimeter to measure the polarity of the power socket for the arrester when the indicator is red. If the N line is on the left and the L line is on the right (facing the socket), the arrester's PE terminal is not grounded. If not, the polarity of the arrester power cord should be reversed. In this case, you should open the power arrester and rectify the polarity of the connection. If the indicator is still red, the arrester's PE terminal is not grounded.

6.3.2 Installing an Ethernet Port Lightning Arrester

Connect an Ethernet port arrester to the equipment to prevent the damage by lightning before connecting an outdoor network cable to the device.

Tools: Phillips screwdrivers or flat-head screwdriver, multimeter, and diagonal pliers

Procedure:

- (1) Tear one side of the protective paper for the double-sided adhesive tape and paste the tape to the enclosure of the Ethernet port arrester.
- (2) Tear the other side of the protective paper for the double-sided adhesive tape and paste the Ethernet port arrester to the enclosure. The paste position for the Ethernet port arrester should be as close to the grounding terminal of the equipment as possible.
- (3) According to the distance between the equipment grounding terminal and the Ethernet port arrester, cut the grounding cable for the Ethernet port arrester and firmly crimp the grounding cable to the grounding terminal of the equipment.
- (4) Use a multimeter to check whether the grounding cable for the arrester is in good contact with the grounding terminal and the enclosure of the equipment.
- (5) Connect the arrester by using an adapter cable (note that the external network cable is connected to the IN end, while the adapter cable connected to the equipment is connected to the OUT end) and check whether the service module LED is normal.
- (6) Use a nylon cable tie to bind the power cords.

Figure 6-5 Installing an Ethernet Port Lightning Arrester

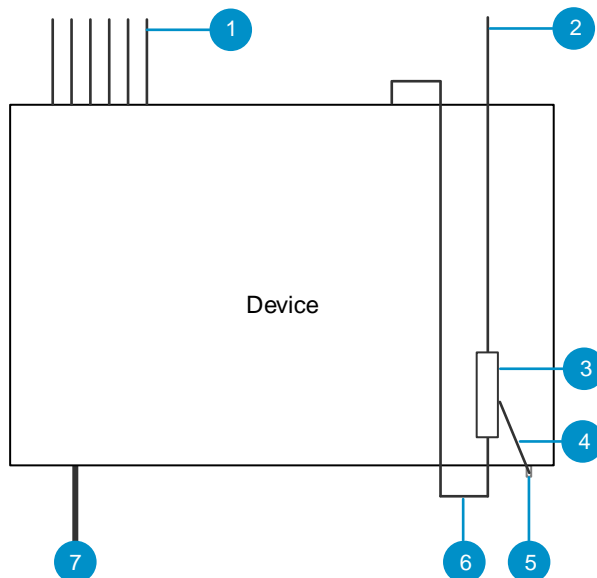

No.	Description
1	Ethernet cable for indoor connection
2	Ethernet cable connected to the outdoor
3	RJ45 port arrester (pasted on the enclosure)
4	Ground cable of the arrester
5	Grounding lug of the equipment
6	RJ45 port adapter cable
7	Power input

Note

- The Ethernet port arrester is only for Ethernet ports with an RJ45 connector.
 - The Ethernet port arrester is not delivered with the equipment. Please purchase it based on actual requirements. The Ethernet port arrester user manual contains technical parameters and maintenance and installation instructions for the Ethernet port arrester. Carefully read this manual before installation.
-
- Pay attention to the following situations during the installation to avoid influencing the performance of the Ethernet port arrester:
 - Reversed installation direction of the arrester. Connect the external network cable to the “IN” end and connect the Ethernet port of the equipment to the “OUT” end.
 - Poor grounding of the arrester. The grounding cable of the arrester should be as short as possible to ensure that it is in good contact with the grounding terminal of the equipment. Use a multimeter to confirm the contact condition after grounding.
 - Incomplete arrester installation. If there is more than one port connected to external power cords, arresters need to be installed on all connection ports for the purpose of surge protection.

6.4 Recommended Cabling

6.4.1 Requirements for the Minimum Bend Radius of an Ethernet Cable

- The bend radius of a fixed power cord, Ethernet cable, or flat cable should be over five times greater than their respective diameters. The bend radius of these cables that are

often bent or plugged should be over seven times greater than their respective diameters.

- The bend radius of a fixed common coaxial cable should be over seven times greater than its diameter. The bend radius of the common coaxial cable that is often bent or plugged should be over 10 times greater than its diameter.
- The bend radius of a fixed high-speed cable (such as SFP+ cable) should be over five times greater than its diameter. The bend radius of the fixed high-speed cable that is often bent or plugged should be over 10 times greater than its diameter.

6.4.2 Requirement for the Minimum Bend Radius of an Optical Cable

- When an optical cable is coiled, the diameter of a fiber tray should be over 25 times greater than the diameter of the optical cable.
- When an optical cable is moved, the bend radius of the optical cable should be over 20 times greater than the diameter of the optical cable.
- When an optical cable is laid, the bend radius of the optical cable should be over 10 times greater than the diameter of the optical cable.

6.4.3 Precautions for Bundling up Cables

- Before cables are bundled, mark labels and stick the labels to cables wherever appropriate.
- Cables should be neatly and properly bundled in the rack without twisting or bending, as shown in [Figure 6-6](#).

Figure 6-6 Binding Cables (I)

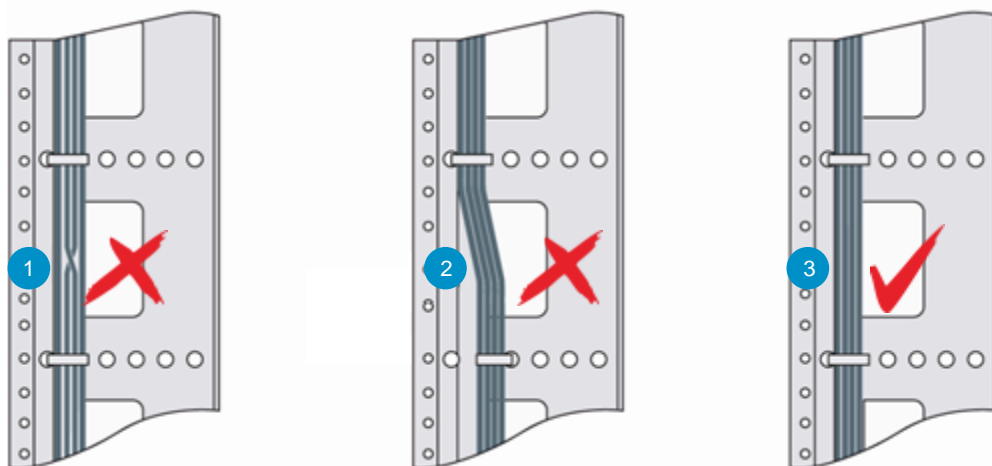

No.	Description
1	In the rack, cables should not be wound up after being bundled.
2	In the rack, cables should not bend after being bundled.
3	In the rack, cables should be neatly and straightly bundled.

- Cables of different types (such as power cords, signal cables, and ground cables) should be separated in cabling and bundling. Mixed bundling is disallowed. When they are close to each other, you are advised to adopt crossover cabling. In the case of parallel cabling, maintain a minimum distance of 30 mm (1.18 in.) between power cords and signal cables.
- The cable management brackets and cabling troughs inside and outside the rack should be smooth without sharp corners.
- The metal hole traversed by cables should have a smooth and fully rounding surface or an insulated lining.
- Use cable ties to bundle up cables properly. Please do not connect two or more cable ties to bundle up cables.
- After bundling up cables with cable ties, cut off the remaining part. The cut should be smooth and trim, without sharp corners, as shown in [Figure 6-7](#).

Figure 6-7 Binding Cables (II)

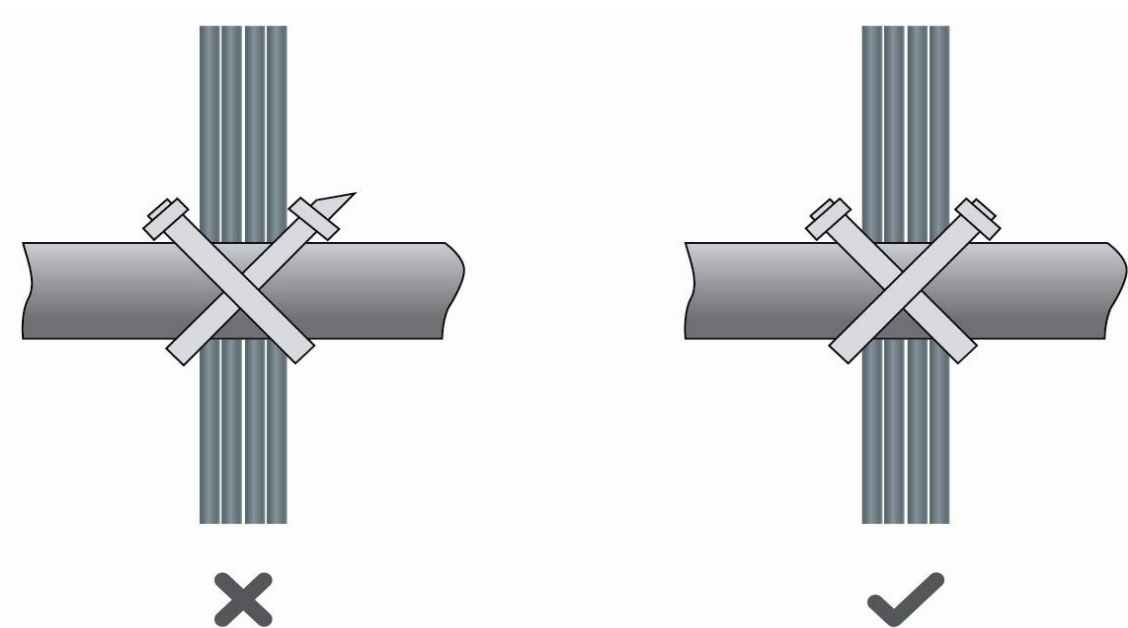

- When cables need to be bent, please bundle them up but do not tie them where the

cables will be bent, as shown in [Figure 6-8](#).

Figure 6-8 Binding Cables (III)

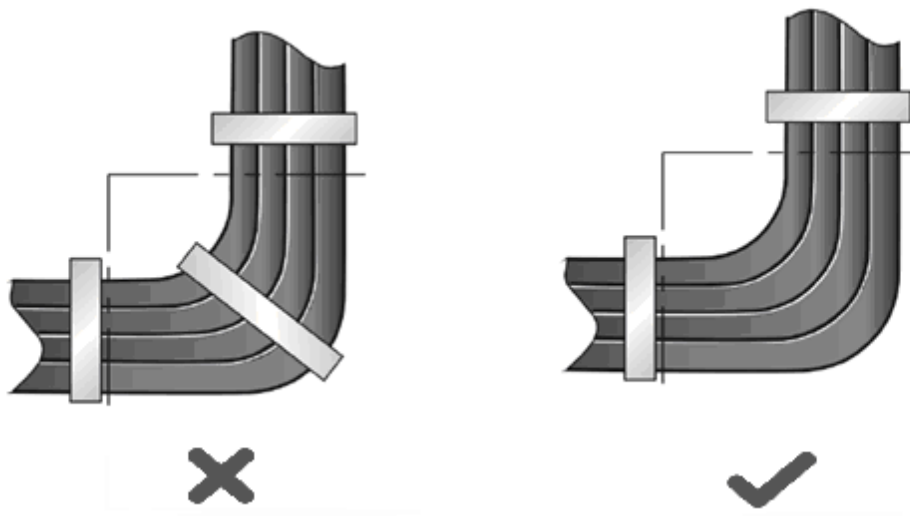

- Cables not to be assembled or remaining parts of cables should be folded and placed in a proper position of the rack or cable trough. The proper position refers to a position that does not affect device running or damage the device or cable.
- Do not bind power cords to the guide rails of moving parts.
- The power cords connecting moving parts such as door grounding cables should be reserved with a margin after being assembled to avoid suffering tension or stress. When the moving part is installed, the remaining cable part should not touch heat sources, sharp corners, or sharp edges. If heat sources cannot be avoided, high-temperature cables should be used.
- When screw threads are used to fasten cable terminals, the anchor or screw must be tightly fastened, as shown in [Figure 6-9](#).

Figure 6-9 Cable Fastening

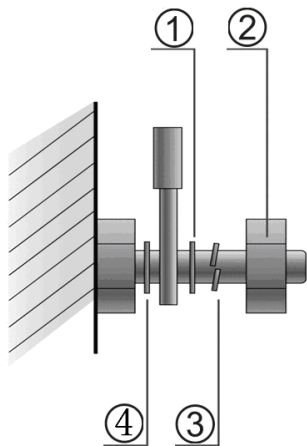

- ① Flat washer ③ Spring washer
- ② Screw nut ④ Flat washer

- Hard power cords should be fastened in the terminal connection area to prevent stress on terminal connection and cable.
- Do not use self-tapping screws to fasten terminals.
- Power cords of the same type and in the same cabling direction should be bundled up into cable bunches, with cables in cable bunches clean and straight.
- Bundle up cables by using cable ties.

Cable Bunch Diameter	Distance Between Every Binding Point
10 mm (0.39 in.)	80 mm to 150 mm (3.15 in. to 5.91 in.)
10 mm to 30 mm (0.39 in. to 1.18 in.)	150 mm to 200 mm (5.91 in. to 7.87 in.)
30 mm (1.18 in.)	200 mm to 300 mm (7.87 in. to 11.81 in.)

- Do not tie cables or bundles in a knot.
- For wiring terminal sockets (such as circuit breakers) with cord end terminals, the metal part of the cord end terminal should not be exposed outside the terminal socket when assembled.